

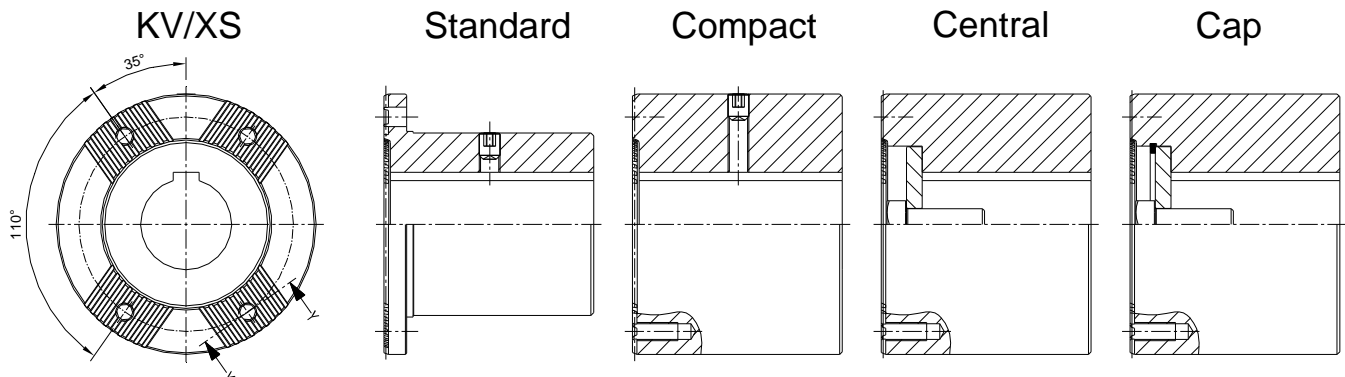

Typenübersicht *Range of types*

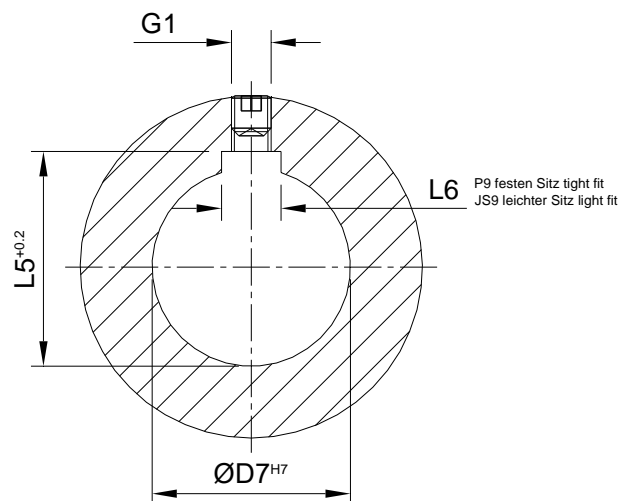

Maßliste Nabe mit Passfeder DIN 6885 *List of dimensions sleeve with key DIN 6885*



Nutenpassung wahlweise in P9 oder JS9 Passung
Nabenbohrung standardmäßig mit H7 Passung. Auf Wunsch jede andere Passung.

Bei fehlender Angaben über die Länge des Wellenstumpfes gilt nach den Regeln der Technik für die richtige Länge L1 des Anschlussflansches und unseren Erfahrungen: $L1 = 1,55 \times \text{ØD7}$. Wobei das Ergebnis dann auf eine Standard Zahl abgerundet wird. (0, 2, 4, 5, 6, 8).

Bei Anschlussflansche der Version B mit relativ großer Nabe kann Maß G eventuell entsprechend kleiner angelegt sein.

Key way fit optional with P9 or JS9. Sleeve hole standard fit H7. All other type of fits on request.

If the length of the shaft is not specified following formula is necessary according the state of art and our know how for the length of L1: $L1 = 1.55 \times \text{ØD7}$. The result have to be rounded down to a standard number. (0, 2, 4, 5, 6, 8).

For companion flange version B with a relative big sleeve, the size G eventually change to one of the smaller size.

Anschlussflansche Companion flanges

SASS



— seit 1935 —

Maßliste Nabe mit Passfeder DIN 6885
List of dimensions sleeve with key DIN 6885

Ø10-Ø39				Ø40-Ø69				Ø70-Ø99				Ø100-148				Ø150-198			
D7	L6	L5	G1	D7	L6	L5	G1	D7	L6	L5	G1	D7	L6	L5	G1	D7	L6	L5	G1
10	3	11,4	M3	40	12	43,3	M10	70	20	74,9	M18	100	28	106,4	M24	150	36	158,4	M24
11	4	12,8	M3	41	12	44,3	M10	71	20	75,9	M18	102	28	108,4	M24	152	40	161,4	M24
12	4	13,8	M3	42	12	45,3	M10	72	20	76,9	M18	104	28	110,4	M24	154	40	163,4	M24
13	5	15,3	M4	43	12	46,3	M10	73	20	77,9	M18	105	28	111,4	M24	155	40	164,4	M24
14	5	16,3	M4	44	12	47,3	M10	74	20	78,9	M18	106	28	112,4	M24	156	40	165,4	M24
15	5	17,3	M4	45	14	48,8	M12	75	20	79,9	M18	108	28	114,4	M24	158	40	167,4	M24
16	5	18,3	M4	46	14	49,8	M12	76	22	81,4	M20	110	28	116,4	M24	160	40	169,4	M24
17	5	19,3	M4	47	14	50,8	M12	77	22	82,4	M20	112	32	119,4	M24	162	40	171,4	M24
18	6	20,8	M5	48	14	51,8	M12	78	22	83,4	M20	114	32	121,4	M24	164	40	173,4	M24
19	6	21,8	M5	49	14	52,8	M12	79	22	84,4	M20	115	32	122,4	M24	165	40	174,4	M24
20	6	22,8	M5	50	14	53,8	M12	80	22	85,4	M20	116	32	123,4	M24	166	40	175,4	M24
21	6	23,8	M5	51	16	55,3	M14	81	22	86,4	M20	118	32	125,4	M24	168	40	177,4	M24
22	6	24,8	M5	52	16	56,3	M14	82	22	87,4	M20	120	32	127,4	M24	170	40	179,4	M24
23	8	26,3	M6	53	16	57,3	M14	83	22	88,4	M20	122	32	129,4	M24	172	45	182,4	M24
24	8	27,3	M6	54	16	58,3	M14	84	22	89,4	M20	124	32	131,4	M24	174	45	184,4	M24
25	8	28,3	M6	55	16	59,3	M14	85	22	90,4	M20	125	32	132,4	M24	175	45	185,4	M24
26	8	29,3	M6	56	16	60,3	M14	86	25	91,4	M24	126	32	133,4	M24	176	45	186,4	M24
27	8	30,3	M6	57	16	61,3	M14	87	25	92,4	M24	128	32	135,4	M24	178	45	188,4	M24
28	8	31,3	M6	58	16	62,3	M14	88	25	93,4	M24	130	32	137,4	M24	180	45	190,4	M24
29	8	32,3	M6	59	18	63,4	M16	89	25	94,4	M24	132	36	140,4	M24	182	45	192,4	M24
30	8	33,3	M6	60	18	64,4	M16	90	25	95,4	M24	134	36	142,4	M24	184	45	194,4	M24
31	10	34,3	M8	61	18	65,4	M16	91	25	96,4	M24	135	36	143,4	M24	185	45	195,4	M24
32	10	35,3	M8	62	18	66,4	M16	92	25	97,4	M24	136	36	144,4	M24	186	45	196,4	M24
33	10	36,3	M8	63	18	67,4	M16	93	25	98,4	M24	138	36	146,4	M24	188	45	198,4	M24
34	10	37,3	M8	64	18	68,4	M16	94	25	99,4	M24	140	36	148,4	M24	190	45	200,4	M24
35	10	38,3	M8	65	18	69,4	M16	95	25	100,4	M24	142	36	150,4	M24	192	45	202,4	M24
36	10	39,3	M8	66	20	70,9	M18	96	28	102,4	M24	144	36	152,4	M24	194	45	204,4	M24
37	10	40,3	M8	67	20	71,9	M18	97	28	103,4	M24	145	36	153,4	M24	195	45	205,4	M24
38	10	41,3	M8	68	20	72,9	M18	98	28	104,4	M24	146	36	154,4	M24	196	45	206,4	M24
39	12	42,3	M10	69	20	73,9	M18	99	28	105,4	M24	148	36	156,4	M24	198	45	208,4	M24

Ø200-Ø238				Ø240-Ø278				Ø280-Ø318				Ø320-Ø358				Ø360-Ø398			
D7	L6	L5	G1	D7	L6	L5	G1	D7	L6	L5	G1	D7	L6	L5	G1	D7	L6	L5	G1
200	45	210,4	M24	240	56	252,4	M30	280	63	292,4	M40	320	70	334,4	M50	360	80	375,4	M60
202	50	213,4	M24	242	56	254,4	M30	282	63	294,4	M40	322	70	336,4	M50	362	80	377,4	M60
204	50	215,4	M24	244	56	256,4	M30	284	63	296,4	M40	324	70	338,4	M50	364	80	379,4	M60
205	50	216,4	M24	245	56	257,4	M30	285	63	297,4	M40	325	70	339,4	M50	365	80	380,4	M60
206	50	217,4	M24	246	56	258,4	M30	286	63	298,4	M40	326	70	340,4	M50	366	80	381,4	M60
208	50	219,4	M24	248	56	250,4	M30	288	63	300,4	M40	328	70	342,4	M50	368	80	383,4	M60
210	50	221,4	M24	250	56	262,4	M30	290	63	302,4	M40	330	70	344,4	M50	370	80	385,4	M60
212	50	223,4	M24	252	56	264,4	M30	292	70	306,4	M50	332	80	347,4	M60	372	80	387,4	M60
214	50	225,4	M24	254	56	266,4	M30	294	70	308,4	M50	334	80	349,4	M60	374	80	389,4	M60
215	50	226,4	M24	255	56	267,4	M30	295	70	309,4	M50	335	80	350,4	M60	375	80	390,4	M60
216	50	227,4	M24	256	56	268,4	M30	296	70	310,4	M50	336	80	351,4	M60	376	80	391,4	M60
218	50	229,4	M24	258	56	260,4	M30	298	70	312,4	M50	338	80	353,4	M60	378	80	393,4	M60
220	50	231,4	M24	260	56	272,4	M30	300	70	314,4	M50	340	80	355,4	M60	380	80	395,4	M60
222	50	233,4	M24	262	63	274,4	M40	302	70	316,4	M50	342	80	357,4	M60	382	90	399,4	M70
224	50	235,4	M24	264	63	276,4	M40	304	70	318,4	M50	344	80	359,4	M60	384	90	401,4	M70
225	50	236,4	M24	265	63	277,4	M40	305	70	319,4	M50	345	80	360,4	M60	385	90	402,4	M70
226	50	237,4	M24	266	63	268,4	M40	306	70	320,4	M50	346	80	361,4	M60	386	90	403,4	M70
228	50	239,4	M24	268	63	270,4	M40	308	70	322,4	M50	348	80	363,4	M60	388	90	405,4	M70
230	50	241,4	M24	270	63	282,4	M40	310	70	324,4	M50	350	80	365,4	M60	390	90	407,4	M70
232	56	244,4	M30	272	63	284,4	M40	312	70	326,4	M50	352	80	367,4	M60	392	90	409,4	M70
234	56	246,4	M30	274	63	286,4	M40	314	70	328,4	M50	354	80	369,4	M60	394	90	411,4	M70
235	56	247,4	M30	275	63	287,4	M40	315	70	329,4	M50	355	80	370,4	M60	395	90	412,4	M70
236	56	248,4	M30	276	63	288,4	M40	316	70	330,4	M50	356	80	371,4	M60	396	90	413,4	M70
238	56	240,4	M30	278	63	280,4	M40	318	70	332,4	M50	358	80	373,4	M60	398	90	415,4	M70

Stand 06-2024

Alle Rechte vorbehalten, kopieren nur mit Genehmigung der Wilhelm Sass KG
Copyright by Wilhelm Sass KG



KV/XS Standard

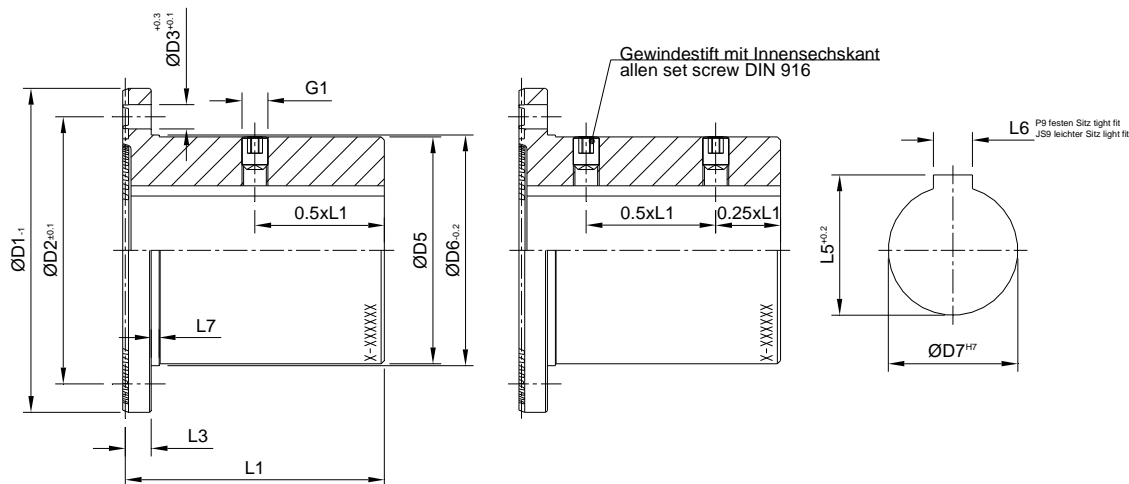

Schnitt section Y-Y

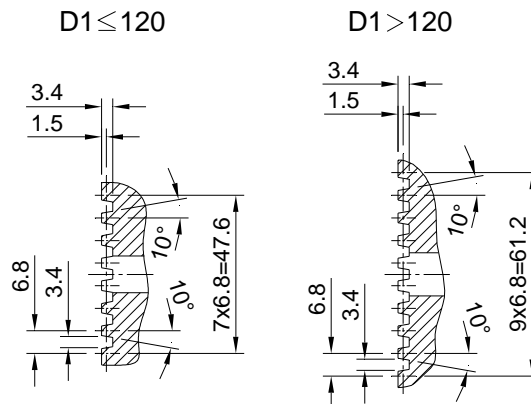
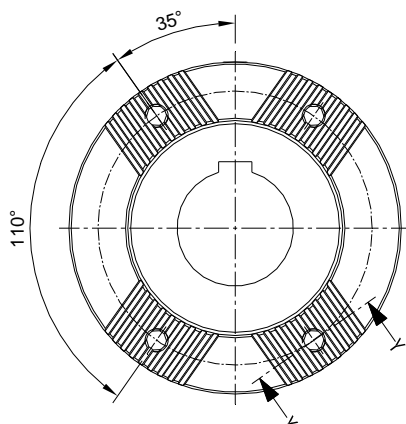

* = Details Nabe + G1 siehe Maßliste Nabe mit Passfeder
* = details sleeve + G1 see list of dimensions sleeve with key

ØD1 mm	L1 mm	ØD7* mm	ØD2 mm	ØD3 mm	L3 mm	L7 mm	ØD5 mm	ØD6 mm	Ver sion	G2 mm	Schrauben bolts	
											Maß size	Mt Nm
100	25-110	20-40	84	Ø8	10	3	69	70.8	A	M8	M8x1x30	36
		41-50										
120	25-130	26-48	100	Ø11	14	5	82	84.1	A	M10	M10x1x40	70
		49-60										
150	35-170	41-65	130	Ø13	16	5	108	110.6	A	M12	M12x1.5x45	120
		66-80										
180	50-205	41-90	150	Ø15	18	5	125	127.5	B	M14	M14x1.5x55	190
200	60-250	50-100	165	Ø15	20	5	140	142.5	B	M14	M14x1.5x55	190



KV/XS Compact

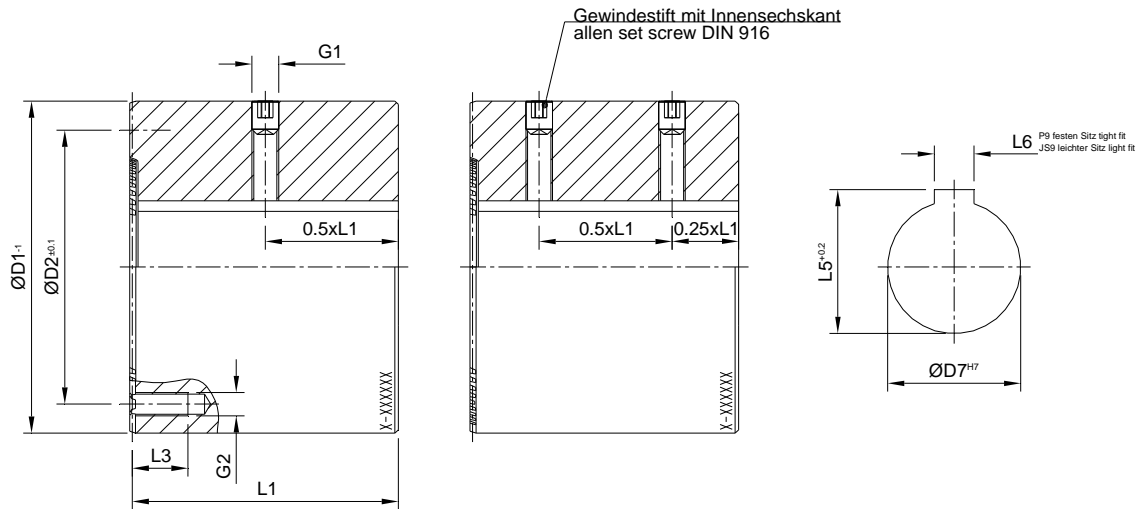

Schnitt section Y-Y

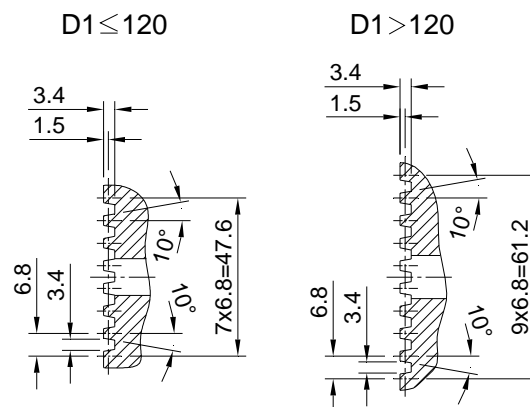
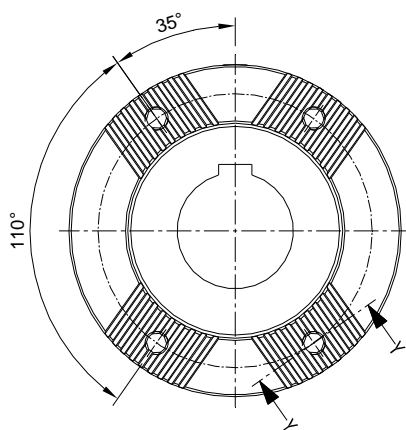

* = Details Nabe + G1 siehe Maßliste Nabe mit Passfeder
 * = details sleeve + G1 see list of dimensions sleeve with key

ØD1 mm	L1 mm	ØD7* mm	ØD2 Mm	L3 mm	Ver sion	G2 mm	Schrauben bolts	
							Maß size	Mt Nm
100	45-110	20-40	84	20	A	M8	M8x20	36
		41-60						
120	45-130	26-50	100	25	A	M10	M10x25	70
		61-70						
150	55-170	41-70	130	25	A	M12	M12x25	120
		71-100						
180	75-205	41-120	150	35	B	M14	M14x35	190
200	90-250	50-130	165	35	B	M14	M14x35	190

Stand 06-2024

Alle Rechte vorbehalten, kopieren nur mit Genehmigung der Wilhelm Sass KG
 Copyright by Wilhelm Sass KG

KV/XS Central

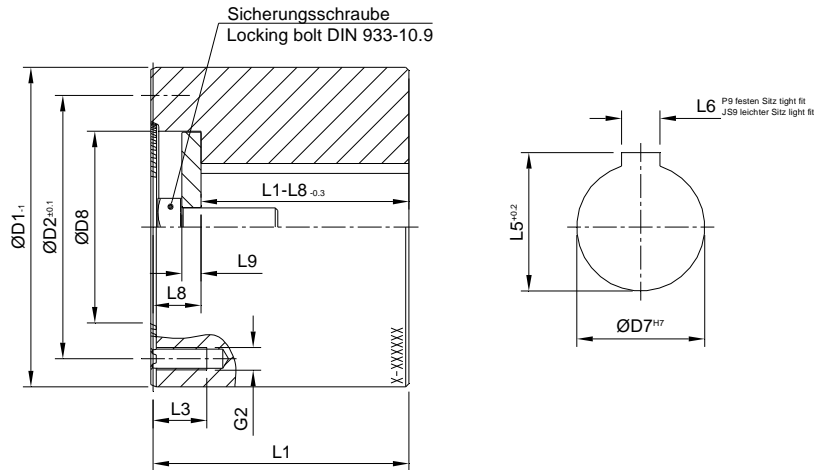

Schnitt section Y-Y

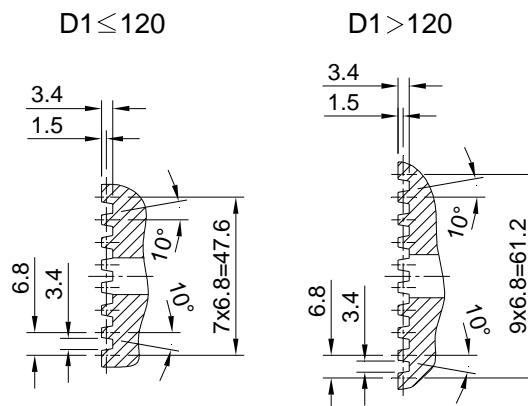
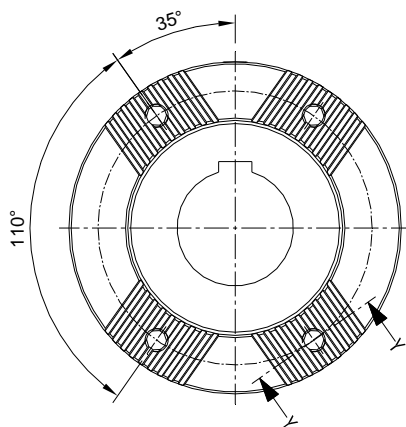

* = Details Nabe siehe Maßliste Nabe mit Passfeder
* = details sleeve see list of dimensions sleeve with key

ØD1 mm	L1 mm	ØD7* mm	ØD2 mm	L3 mm	L8 mm	L9 mm	ØD8 mm	G2 mm	Schrauben bolts	
									Maß size	Mt Nm
100	45-110	20-44	84	20	20	5	49	M8	M8x20	36
120	45-130	20-64	100	25	20	8	69	M10	M10x25	70
150	55-170	30-80	130	25	20	8	82	M12	M12x25	120
180	75-205	40-90	150	35	25	10	99	M14	M14x35	190
200	90-250	50-108	165	35	30	12	119	M14	M14x35	190

Stand 06-2024

Alle Rechte vorbehalten, kopieren nur mit Genehmigung der Wilhelm Sass KG
Copyright by Wilhelm Sass KG



KV/XS Cap

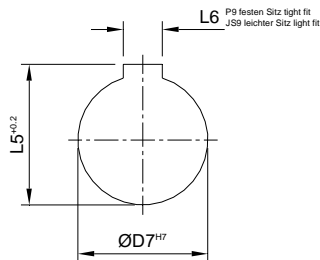
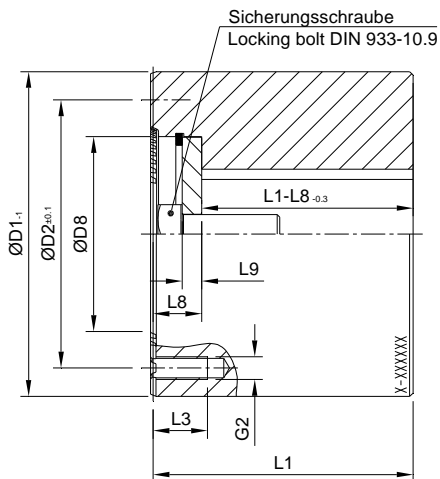

Schnitt section Y-Y

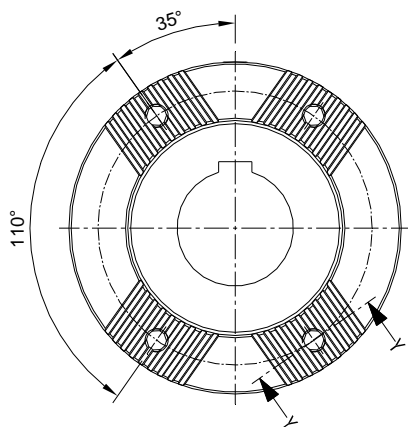

$D1 \leq 120$

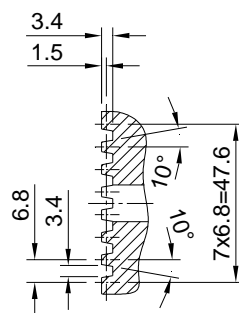

$D1 > 120$

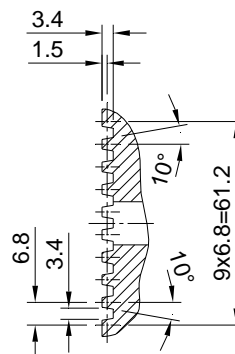

* = Details Nabe siehe Maßliste Nabe mit Passfeder
* = details sleeve see list of dimensions sleeve with key

ØD1 mm	L1 mm	ØD7* mm	ØD2 mm	ØD3 mm	L3 mm	L8 mm	L9 mm	ØD8 mm	G2 mm	Schrauben bolts	
										Maß size	Mt Nm
100	45-110	20-44	84	Ø8	20	20	5	49	M8	M8x20	36
120	45-130	20-64	100	Ø11	25	20	8	69	M10	M10x25	70
150	55-170	30-80	130	Ø13	25	20	8	82	M12	M12x25	120
180	75-205	40-90	150	Ø15	35	25	10	99	M14	M14x35	190
200	90-250	50-108	165	Ø15	35	30	12	119	M14	M14x35	190

Stand 06-2024

Alle Rechte vorbehalten, kopieren nur mit Genehmigung der Wilhelm Sass KG
Copyright by Wilhelm Sass KG