

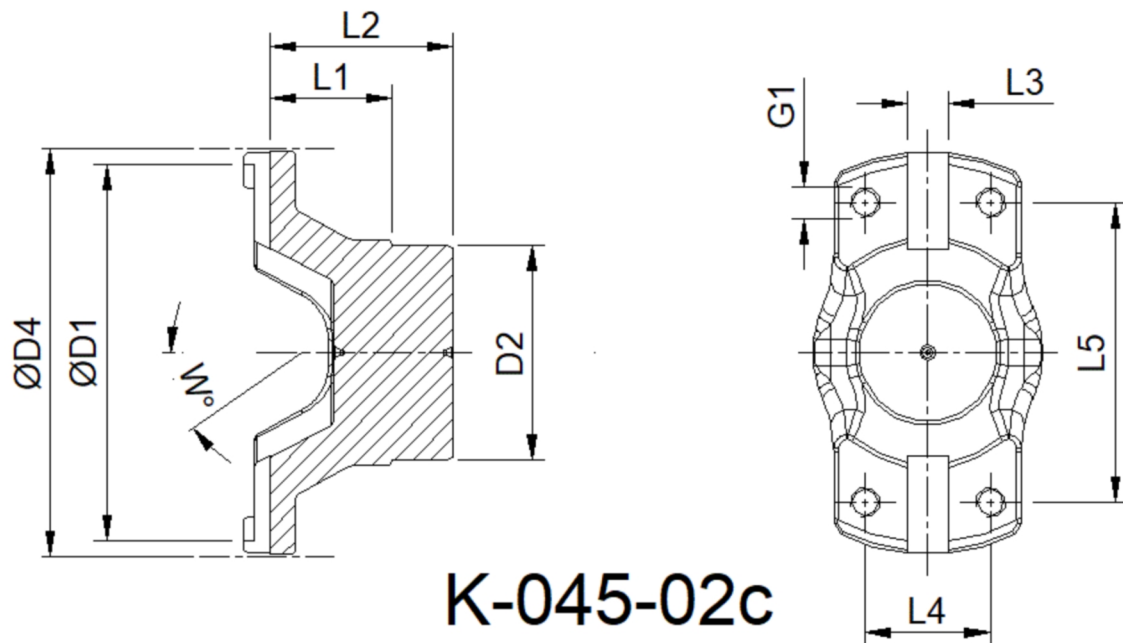

Artikelnummer identification code	0450289	Fotos und Bilder dienen nur der Veranschaulichung. Abweichungen in Farbe und Form sind möglich! Photos and figures are for illustration onla. Colour and design ist not guaranteed.
Schweisszapfen RA=88,3 / L1=66,5		tube yoke TC 88,3 / L1=66,5
für KR 8,5C		for UJ 8,5c



K-045-02c

Gewicht: 2,700 kg

D1	165,10	L1	66,50	G1	1/2'	W	25°
D2	88,30	L3	15,85				
D4	175,00	L4	71,42				
		L5	123,80				