

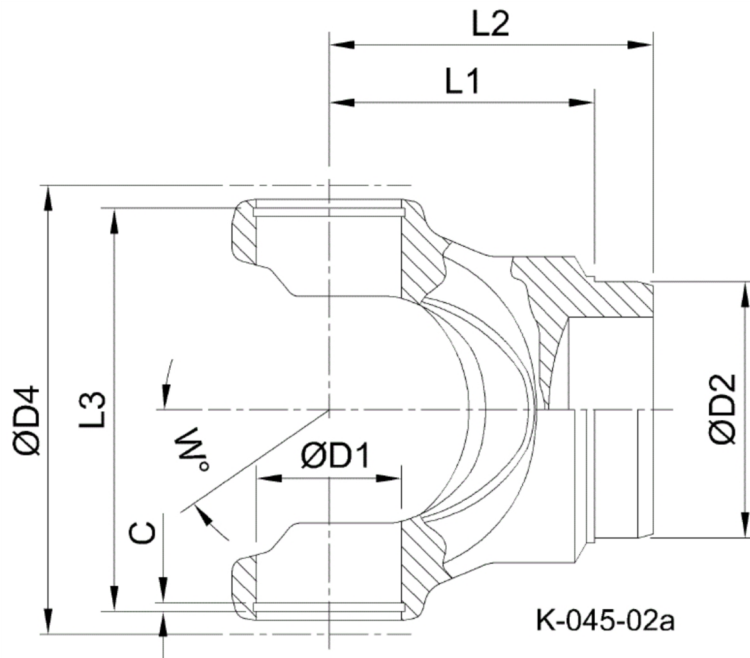

Artikelnummer identification code	<h1>0450200</h1>	Fotos und Bilder dienen nur der Veranschaulichung. Abweichungen in Farbe und Form sind möglich!  Photos and figures are for illustration onla. Colour and design ist not guaranteed.
Schweisszapfen RA=112,3 / L1=95 für KR 52x147,2	tube yoke tc=112,3 / L1=95 for UJ 52x147,2	



Gewicht: 7,500 kg

D1	52,00	L1	95,00	W	35°
D2	112,30	L3	151,00		
D4	169,00				