

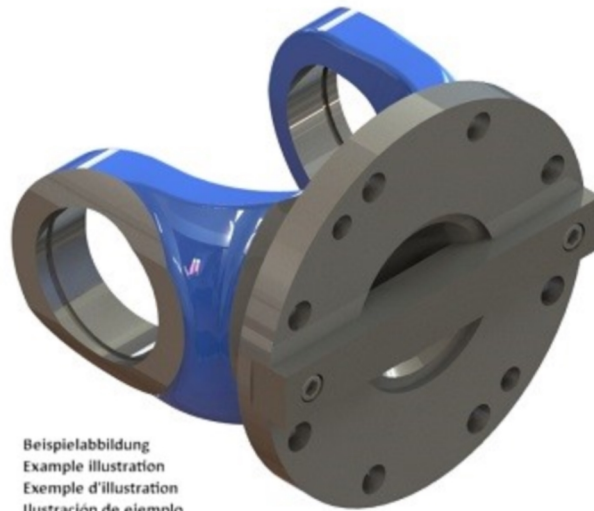

Artikelnummer identification code	<b>0030567</b>	Fotos und Bilder dienen nur der Veranschaulichung. Abweichungen in Farbe und Form sind möglich!  Photos and figures are for illustration onla. Colour and design ist not guaranteed.
Gabelflansch DIN 250/8-19+QK+2xM18 / L1=125	flange yoke DIN 250/8-19+key+2xM18 / L1=125	
für KR 90x192	for UJ 90x192	

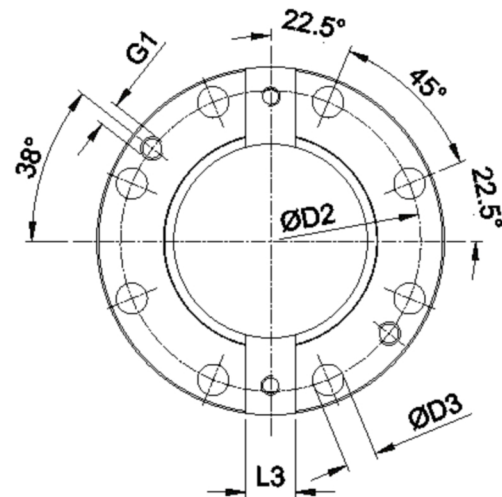

Beispielabbildung  
Example illustration  
Exemple d'illustration  
Ilustración de ejemplo  
Пример иллюстрации

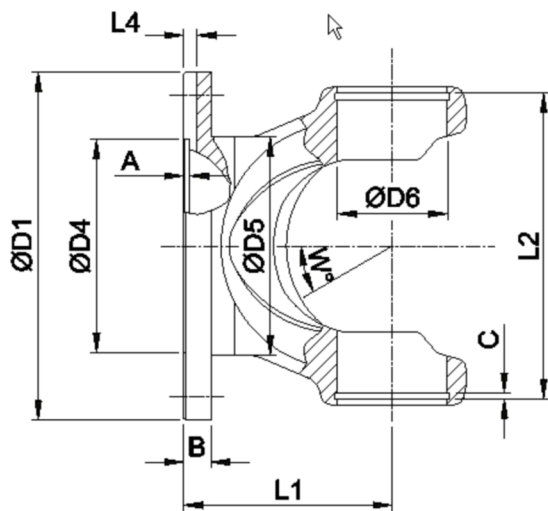

**K-003-31c**

Gewicht: 19,000 kg

D1	250,00	L1	125,00	A	6,00	W	15°
D2	218,00	L2	12,50	B	25,00		
D3	19,00	L3	40,00	G1	M18		
D4	105,00	L4	12,50				
D6	90,00						
D8	204,00						