

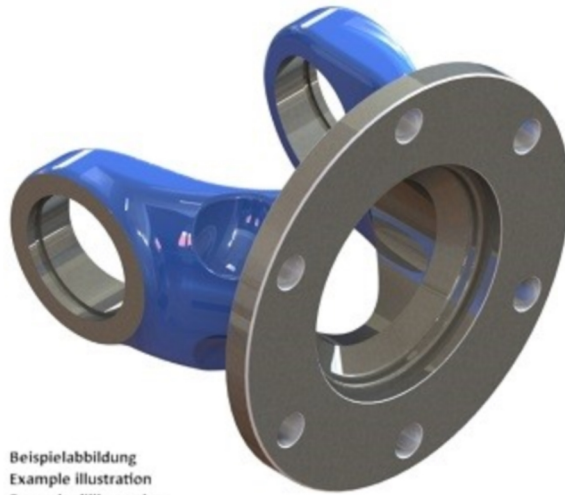

Artikelnummer identification code	0030275-2	Fotos und Bilder dienen nur der Veranschaulichung. Abweichungen in Farbe und Form sind möglich! Photos and figures are for illustration onla. Colour and design ist not guaranteed.
Gabelflansch DIN 100/6-8 / L1=58	flange yoke DIN 100/6-8 / L1=58	
für KR 30x81,8 - Kalotte durchb. 40 mm	for UJ 30x81,8 - hole in the carlotte 40 mm	

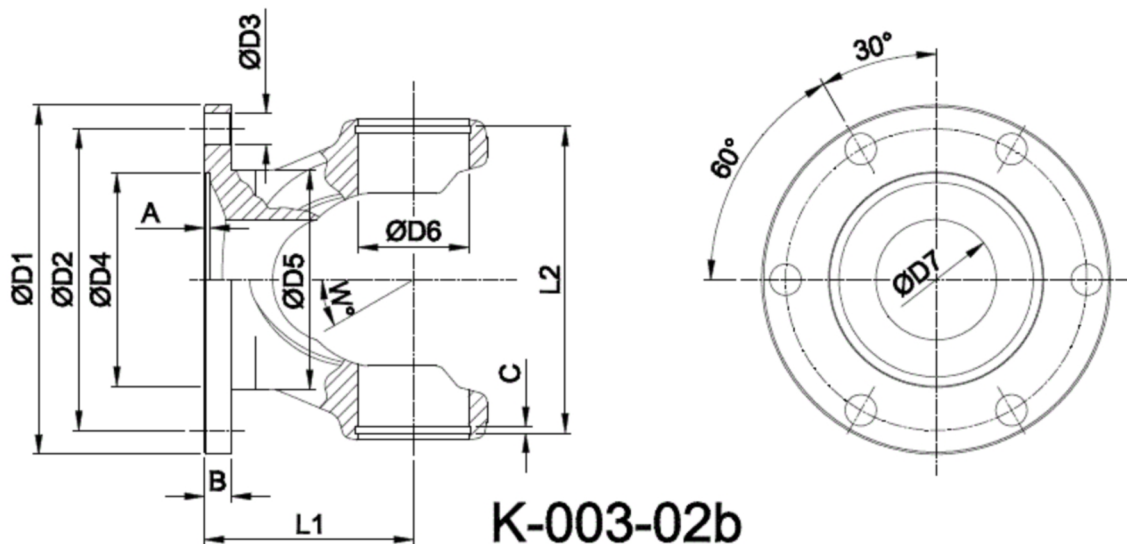

Beispielabbildung
Example illustration
Exemple d'illustration
Ilustración de ejemplo
Пример иллюстрации



Gewicht: 0,830 kg

D1	100,00	L1	58,00	A	3,00	W	35°
D2	84,00	L2	84,60	B	7,00		
D3	8,00			C	2,00		
D4	57,00						
D5	63,00						
D6	30,00						
D7	40,00						